

Functional characteristics



Dimensional class:

medium



Standard colour:

green



Dimensions:

18.4 x 15.5 mm (.724 x .610 in)



Max approved wire size:

solid: 2.5 mm² (VDE); 12 AWG (UL)

stranded: 2.5 mm² (VDE); 12 AWG (UL)

Clamp opening size:

2.5 x 2.4 mm (.098 x .094 in)



Versions:

side stackable,
modular,



locking screw flanges

Single mould poles:

from 2 to 25 (modular and side stackable)

from 2 to 24 (locking screw flanges)



Pitches:

metric 5 mm, 7.5 mm, 10 mm

(.197 in, .295 in, .394 in)



imperial 5.08 mm, 7.62 mm, 10.16 mm

(.200 in, .300 in, .400 in)

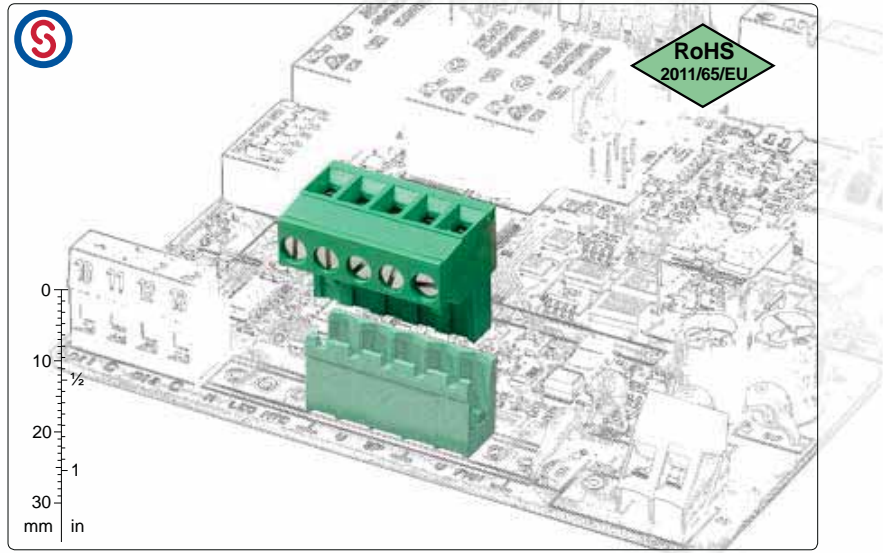

pitch 5/5.08 mm
from 2 to 25 poles
modular



pitch 7.5/7.62 mm
from 2 to 12 poles
side stackable



from 2 to 24 poles
locking screw flanges



available accessories:
from 2 to 9 poles
BSC for rising clamp



CIF-LC1
coding splines

Brief description

The **CIF** female connector series makes it possible to use wires up to 2.5mm² (12 AWG) and consequently a current range of **16A certified** can be reached.

It is available in 5 mm (.197 in), 7.5 mm (.295 in) and 10 mm (.394 in) metric pitches and in 5.08 mm (.200 in), 7.62 (.300 in) and 10.16 mm (.400 in) Imperial pitches, in monolithic blocks from 2 to 25 poles, in side-stackable or modular versions or with flanges.

The **CTM** connector series for PCBs is characterized by an asymmetric profile, so mistakes are prevented when connections are made with the relative **CIM**, **CPM** or **CRM** male connectors soldered to the board or the **CGM** connectors with screw connection to the wire. Further safety when

connecting can be obtained by using the CIF-LC1 and CIM-SCI Coding Splines and Coding Clips (see page 20-21) or COF-SP1 polarization pegs.

It is possible to side-stack or assemble the basic modular connectors in order to obtain any number of poles without losing the pitch. By taking advantage of this particular characteristic a minimum stock of basic connectors can be kept.

It is simple to manage the product, the warehouse and the assembly with the Kit packages because several versions can be received with only one code, the part-numbers are significantly reduced and the risk of making mistakes is also reduced.



Characteristics of components

- M3 nickel plated copper alloy screw.
- Nickel-plated copper alloy rising clamp.
- Polyamide housing.
Standard colour: GREEN.
V0 self-extinguishing according to UL 94.
Chlorinated solvents resistant,
with no phosphor, dioxin or detrimental to health halogens.
Material Group I (CTI ≥ 600 V)
- Leadfree tin-plated copper alloy spring.

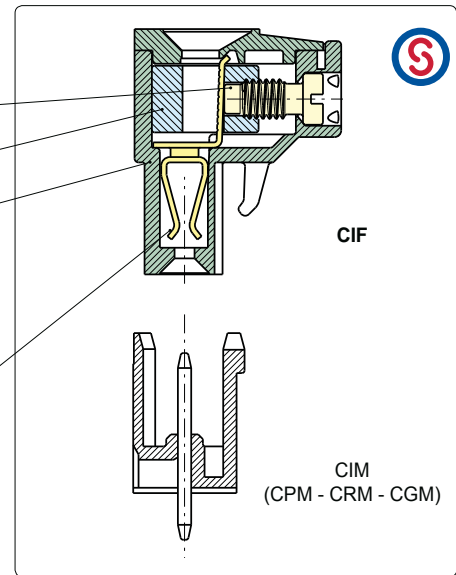

Mechanical characteristics

Insertion force per pole	max 3 N (.674 lbf)
Withdrawal force per pole	min 1,5 N (.337 lbf)
Recommended/highest tightening torque	0.5/0.6 Nm (4.42/5.30 lbf-in)
Stripping length	6 ÷ 7.5 mm (.24 ÷ .30 in)
Operating temperature range	-40 °C ÷ +110 °C (-40 °F ÷ +230 °F)
Climatic category	40/110/21 according to EN 60068-1

Electric characteristics*

Solid wire section	0.05 ÷ 2.5 mm ² (VDE, IMQ)* 30÷12 AWG (UL)*
Stranded wire section	0.05 ÷ 2.5 mm ² (VDE, IMQ)* 30÷12 AWG (UL)*
Rated voltage for 5 mm (.197 in) and 5.08 mm (.200 in) pitch	320 V (IMQ)*
Rated voltage for 7.5 mm (.295 in) and 7.62 mm (.300 in) pitch	500 V (IMQ)*
Rated voltage for 10 mm (.394 in) and 10.16 mm (.400 in) pitch	800 V (IMQ)*
Rated current	16 A (IMQ)*
Contact resistance	<15 mΩ
Insulation resistance	>10 ⁹ Ω (500V DC)

*All the a.m. data refer to the highest values amongst the certificated ones.

V voltage, I current values and tightening torque are related to the norms to be applied to the product and to its use.

Approvals

IEC-EN	IEC:	for 5 mm and 5.08 mm pitch: 200 V - 16 A - 2.5 mm ² - T110 - 4kV - 3 / 320 V - 16 A - 2.5 mm ² - T110 - 4kV - 2
	EN 61984	for 7.5 mm and 7.62 mm pitch: 320 V - 16 A - 2.5 mm ² - T110 - 6kV - 3 / 500 V - 16 A - 2.5 mm ² - T110 - 6kV - 2
		for 10 mm and 10.16 mm pitch: 500 V - 16 A - 2.5 mm ² - T110 - 8kV - 3 / 800 V - 16 A - 2.5 mm ² - T110 - 8kV - 2

UL US	UL:	300 V - 15 A - 30÷12 AWG - 7 lbf-in for 5 mm, 5.08 mm, 7.5 mm and 7.62 mm pitch
	File E167473	600 V - 15 A - 30÷12 AWG - 7 lbf-in for 10 mm and 10.16 mm pitch
		Application values for end-use equipment have to be in accordance to UL norms and applicable to it.

VDE	VDE:	for 5 mm and 5.08 mm pitch: 250 V - 16 A - 2.5 mm ² - T110 - 2,5kV - 2
	File n. 40027448	for 7.5 mm and 7.62 mm pitch: 500 V - 16 A - 2.5 mm ² - T110 - 4kV - 2
		for 10 mm and 10.16 mm pitch: 750 V - 16 A - 2.5 mm ² - T110 - 6kV - 2

IMQ	IMQ:	for 5 mm and 5.08 mm pitch: 200 V - 12 A - 2.5 mm ² - T110 - 4kV - 3 / 320 V - 12 A - 2.5 mm ² - T110 - 4kV - 2
	File n. EM672	for 7.5 mm and 7.62 mm pitch: 320 V - 12 A - 2.5 mm ² - T110 - 6kV - 3 / 500 V - 12 A - 2.5 mm ² - T110 - 6kV - 2
		for 10 mm and 10.16 mm pitch: 500 V - 12 A - 2.5 mm ² - T110 - 8kV - 3 / 800 V - 12 A - 2.5 mm ² - T110 - 8kV - 2

CSA	CSA:	300 V - 15 A - 30÷12 AWG for 5 mm, 5.08 mm, 7.5 mm and 7.62 mm pitch
	File LR102896	600 V - 15 A - 30÷12 AWG for 10 mm and 10.16 mm pitch

See also "Certifications", page 8

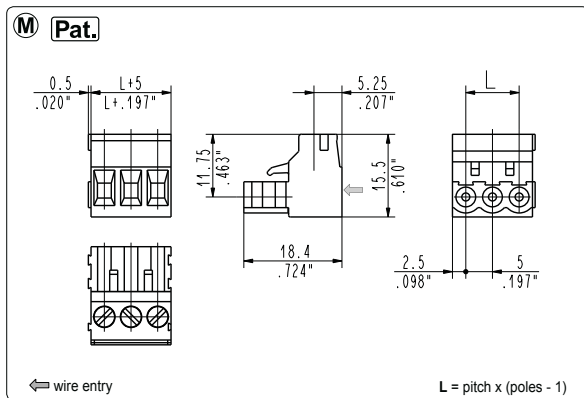

CIF_OM1 modular female

5 mm / .197" pitch

Poles	Code	Pcs/pack.	W [kg]*	Pcs/Ind.**	W [kg]*
02	CIF020M1	500	2,08	1500	6,24
03	CIF030M1	400	2,50	1000	6,24
04	CIF040M1	300	2,50	750	6,24
05	CIF050M1	250	2,60	750	7,80
06	CIF060M1	200	2,50	1000	12,48
07	CIF070M1	175	2,55	1000	14,56
08	CIF080M1	150	2,50	1000	16,64
09	CIF090M1	125	2,34	1000	18,72
10	CIF100M1	100	2,08	500	10,40
11	CIF110M1	100	2,29	500	11,44
12	CIF120M1	75	1,87	500	12,48
13	CIF130M1	75	2,03	500	13,52
14	CIF140M1	75	2,18	500	14,56
15	CIF150M1	75	2,34	500	15,60
16	CIF160M1	75	2,50	500	16,64
17	CIF170M1	50	1,77	500	17,68
18	CIF180M1	50	1,87	250	9,36
19	CIF190M1	50	1,98	250	9,88
20	CIF200M1	50	2,08	250	10,40
21	CIF210M1	50	2,18	250	10,92
22	CIF220M1	50	2,29	250	11,44
23	CIF230M1	50	2,39	250	11,96
24	CIF240M1	50	2,50	250	12,48
25	CIF250M1	50	2,60	250	13,00

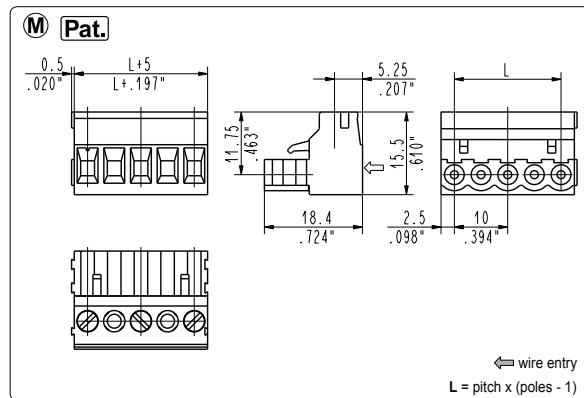

CIF_OM2 modular female

10 mm / .394" pitch

Poles	Code	Pcs/pack.	W [kg]*	Pcs/Ind.**	W [kg]*
01	CIF010M2	500	1,18	1000	2,35
02	CIF020M2	400	0,28	750	3,53
03	CIF030M2	250	0,28	500	3,53
04	CIF040M2	175	1,76	1000	9,40
05	CIF050M2	125	1,47	500	5,88
06	CIF060M2	100	1,41	500	7,05
07	CIF070M2	75	1,23	500	8,23
08	CIF080M2	75	1,41	500	9,40
09	CIF090M2	50	1,06	500	10,58
10	CIF100M2	50	1,18	250	5,88
11	CIF110M2	50	1,29	250	6,46
12	CIF120M2	50	1,41	250	7,05
13	CIF130M2	50	1,53	250	7,64

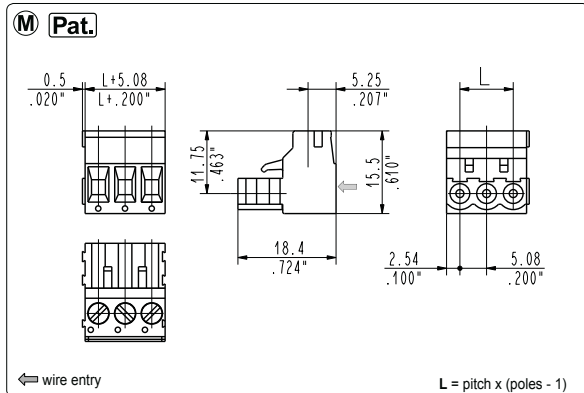

CIF_OM5 modular female

5.08 mm / .200" pitch

Poles	Code	Pcs/pack.	W [kg]*	Pcs/Ind.**	W [kg]*
02	CIF020M5	500	2,08	1500	6,24
03	CIF030M5	400	2,50	1000	6,24
04	CIF040M5	300	2,50	750	6,24
05	CIF050M5	250	2,60	750	7,80
06	CIF060M5	200	2,50	1000	12,48
07	CIF070M5	175	2,55	1000	14,56
08	CIF080M5	150	2,50	1000	16,64
09	CIF090M5	125	2,34	1000	18,72
10	CIF100M5	100	2,08	500	10,40
11	CIF110M5	100	2,29	500	11,44
12	CIF120M5	75	1,87	500	12,48
13	CIF130M5	75	2,03	500	13,52
14	CIF140M5	75	2,18	500	14,56
15	CIF150M5	75	2,34	500	15,60
16	CIF160M5	75	2,50	500	16,64
17	CIF170M5	50	1,77	500	17,68
18	CIF180M5	50	1,87	250	9,36
19	CIF190M5	50	1,98	250	9,88
20	CIF200M5	50	2,08	250	10,40
21	CIF210M5	50	2,18	250	10,92
22	CIF220M5	50	2,29	250	11,44
23	CIF230M5	50	2,39	250	11,96
24	CIF240M5	50	2,50	250	12,48
25	CIF250M5	50	2,60	250	13,00

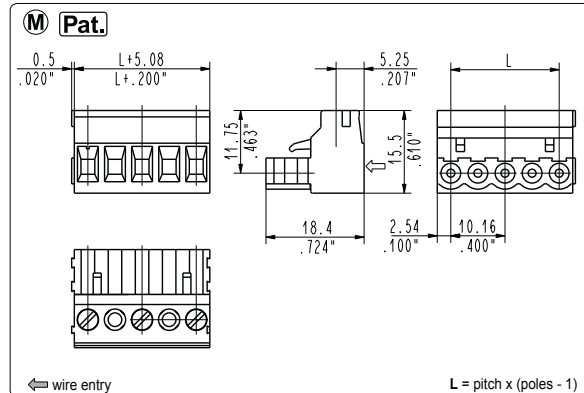

CIF_OM6 modular female

10.16 mm / .400" pitch

Poles	Code	Pcs/pack.	W [kg]*	Pcs/Ind.**	W [kg]*
01	CIF010M6	500	1,18	1000	2,35
02	CIF020M6	400	0,28	750	3,53
03	CIF030M6	250	0,56	500	3,53
04	CIF040M6	175	1,76	1000	9,40
05	CIF050M6	125	1,47	500	5,88
06	CIF060M6	100	1,41	500	7,05
07	CIF070M6	75	1,23	500	8,23
08	CIF080M6	75	1,41	500	9,40
09	CIF090M6	50	1,06	500	10,58
10	CIF100M6	50	1,18	250	5,88
11	CIF110M6	50	1,29	250	6,46
12	CIF120M6	50	1,41	250	7,05
13	CIF130M6	50	1,53	250	7,64

*W [kg]: approximate weight per box in kg

**industrial packaging: add "-00000E" at standard code

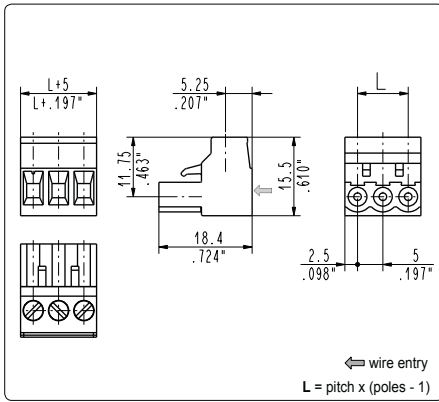

CIF_001 side stackable female

5 mm / .197" pitch				
Poles	Code	Pcs/pack.	W [kg]*	Pcs/Ind.** W [kg]*
02	CIF02001	500	2,08	1500 6,24
03	CIF03001	400	2,50	1000 6,24
04	CIF04001	300	2,50	750 6,24
05	CIF05001	250	2,60	750 7,80
06	CIF06001	200	2,50	500 6,24
07	CIF07001	175	2,55	500 7,28
08	CIF08001	150	2,50	500 8,32
09	CIF09001	125	2,34	250 4,68
10	CIF10001	100	2,08	250 5,20
11	CIF11001	100	2,29	250 5,72
12	CIF12001	75	1,87	250 6,24
13	CIF13001	75	2,03	250 6,76
14	CIF14001	75	2,18	250 7,28
15	CIF15001	75	2,34	250 7,80
16	CIF16001	75	2,50	250 8,32
17	CIF17001	50	1,77	250 8,84
18	CIF18001	50	1,87	250 9,36
19	CIF19001	50	1,98	125 4,94
20	CIF20001	50	2,08	125 5,20
21	CIF21001	50	2,18	125 5,46
22	CIF22001	50	2,29	125 5,72
23	CIF23001	50	2,39	125 5,98
24	CIF24001	50	2,50	125 6,24
25	CIF25001	50	2,60	125 6,50

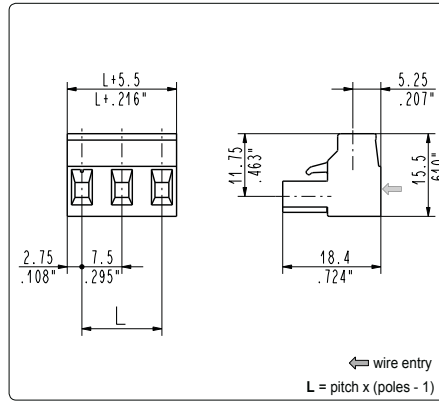

CIF_003 side stackable female

7.5 mm / .295" pitch				
Poles	Code	Pcs/pack.	W [kg]*	Pcs/Ind.** W [kg]*
02	CIF02003	400	1,83	1000 4,58
03	CIF03003	250	1,72	1000 6,87
04	CIF04003	200	1,83	500 4,58
05	CIF05003	150	1,72	500 5,73
06	CIF06003	125	1,72	250 3,44
07	CIF07003	100	1,60	250 4,01
08	CIF08003	75	1,37	250 4,58
09	CIF09003	75	1,55	250 5,15
10	CIF10003	75	1,72	250 5,73
11	CIF11003	50	1,26	250 6,30
12	CIF12003	50	1,37	250 6,87

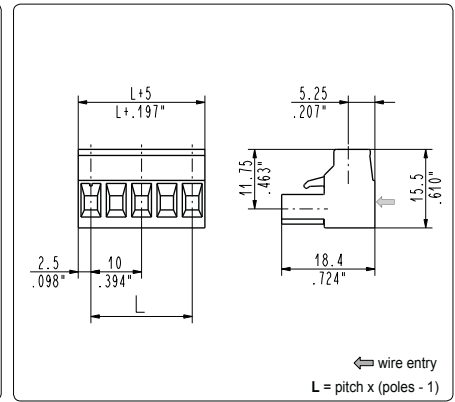

CIF_002 side stackable female

10 mm / .394" pitch				
Poles	Code	Pcs/pack.	W [kg]*	Pcs/Ind.** W [kg]*
02	CIF02002	400	2,06	1000 5,16
03	CIF03002	250	1,94	750 5,81
04	CIF04002	175	1,81	500 5,16
05	CIF05002	125	1,61	250 3,23
06	CIF06002	100	1,55	250 3,87
07	CIF07002	75	1,35	250 4,52
08	CIF08002	75	1,55	250 5,16
09	CIF09002	50	1,16	250 5,81
10	CIF10002	50	1,29	250 6,45
11	CIF11002	50	1,42	250 7,01
12	CIF12002	50	1,55	250 7,74
13	CIF13002	50	1,68	250 8,39

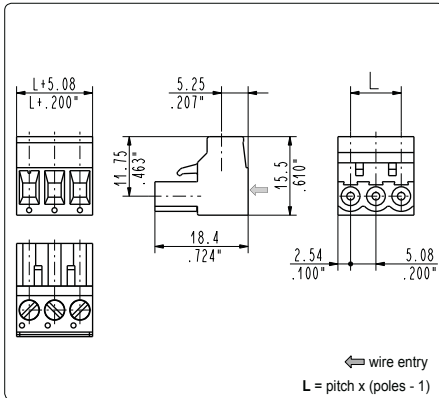

CIF_005 side stackable female

5.08 mm / .200" pitch				
Poles	Code	Pcs/pack.	W [kg]*	Pcs/Ind.** W [kg]*
02	CIF02005	500	2,08	1500 6,24
03	CIF03005	400	2,50	1000 6,24
04	CIF04005	300	2,50	750 6,24
05	CIF05005	250	2,60	750 7,80
06	CIF06005	200	2,50	500 6,24
07	CIF07005	175	2,55	500 7,28
08	CIF08005	150	2,50	500 8,32
09	CIF09005	125	2,34	250 4,68
10	CIF10005	100	2,08	250 5,20
11	CIF11005	100	2,29	250 5,72
12	CIF12005	75	1,87	250 6,24
13	CIF13005	75	2,03	250 6,76
14	CIF14005	75	2,18	250 7,28
15	CIF15005	75	2,34	250 7,80
16	CIF16005	75	2,50	250 8,32
17	CIF17005	50	1,77	250 8,84
18	CIF18005	50	1,87	250 9,36
19	CIF19005	50	1,98	125 4,94
20	CIF20005	50	2,08	125 5,20
21	CIF21005	50	2,18	125 5,46
22	CIF22005	50	2,29	125 5,72
23	CIF23005	50	2,39	125 5,98
24	CIF24005	50	2,50	125 6,24
25	CIF25005	50	2,60	125 6,50

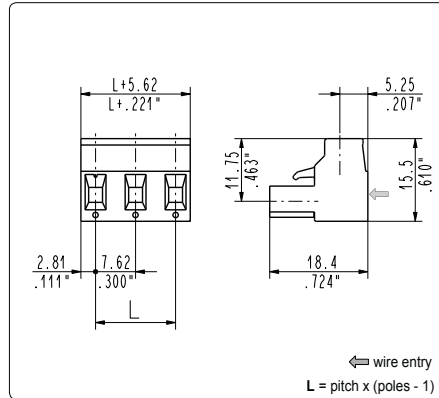

CIF_007 side stackable female

7.62 mm / .300" pitch				
Poles	Code	Pcs/pack.	W [kg]*	Pcs/Ind.** W [kg]*
02	CIF02007	400	1,91	1000 4,78
03	CIF03007	250	1,79	1000 7,17
04	CIF04007	200	1,91	500 4,78
05	CIF05007	150	1,79	500 5,98
06	CIF06007	125	1,79	250 3,59
07	CIF07007	100	1,67	250 4,18
08	CIF08007	75	1,43	250 4,78
09	CIF09007	75	1,61	250 5,38
10	CIF10007	75	1,79	250 5,98
11	CIF11007	50	1,31	250 6,57
12	CIF12007	50	1,43	250 7,17

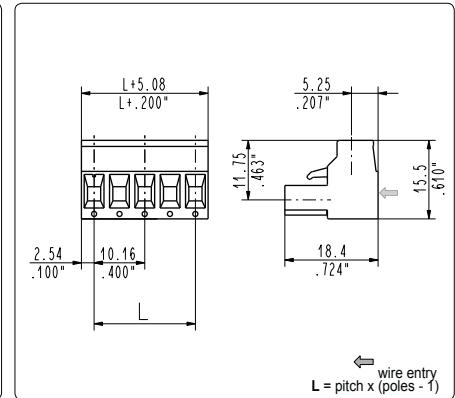

CIF_006 side stackable female

10.16 mm / .400" pitch				
Poles	Code	Pcs/pack.	W [kg]*	Pcs/Ind.** W [kg]*
02	CIF02006	400	2,06	1000 5,16
03	CIF03006	250	1,94	750 5,81
04	CIF04006	175	1,81	500 5,16
05	CIF05006	125	1,61	250 3,23
06	CIF06006	100	1,55	250 3,87
07	CIF07006	75	1,35	250 4,52
08	CIF08006	75	1,55	250 5,16
09	CIF09006	50	1,16	250 5,81
10	CIF10006	50	1,29	250 6,45
11	CIF11006	50	1,42	250 7,01
12	CIF12006	50	1,55	250 7,74
13	CIF13006	50	1,68	250 8,39

Modular version, combinable 2 + ∞ poles Pat. Patented

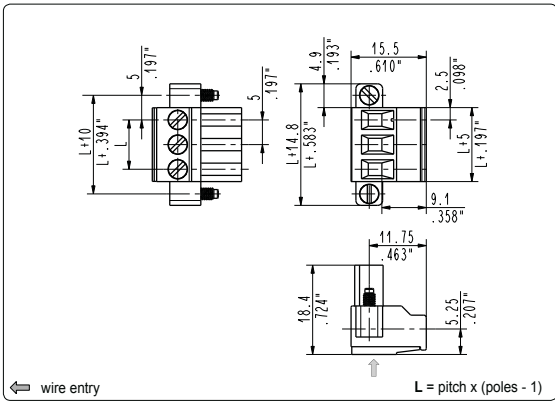

CIF_0V1 locking screw flanges, female

5 mm / .197" pitch

Poles	Code	Pcs/pack.	W [kg]*	Pcs/Ind.**	W [kg]*
02	CIF020V1	300	1,49	1000	4,96
03	CIF030V1	250	1,76	750	5,28
04	CIF040V1	200	1,82	500	4,56
05	CIF050V1	175	1,96	500	5,60
06	CIF060V1	150	1,99	500	6,64
07	CIF070V1	125	1,92	250	3,84
08	CIF080V1	100	1,74	250	4,36
09	CIF090V1	100	1,95	250	4,88
10	CIF100V1	75	1,62	250	5,40
11	CIF110V1	75	1,78	250	5,92
12	CIF120V1	75	1,93	250	6,44
13	CIF130V1	75	2,09	250	6,96
14	CIF140V1	75	2,24	250	7,48
15	CIF150V1	50	1,60	125	4,00
16	CIF160V1	50	1,70	125	4,26
17	CIF170V1	50	1,81	125	4,52
18	CIF180V1	50	1,91	125	4,78
19	CIF190V1	50	2,02	125	5,04
20	CIF200V1	50	2,12	125	5,30
21	CIF210V1	50	2,22	125	5,56
22	CIF220V1	50	2,33	125	5,82
23	CIF230V1	50	2,43	125	6,08
24	CIF240V1	50	2,54	125	6,34

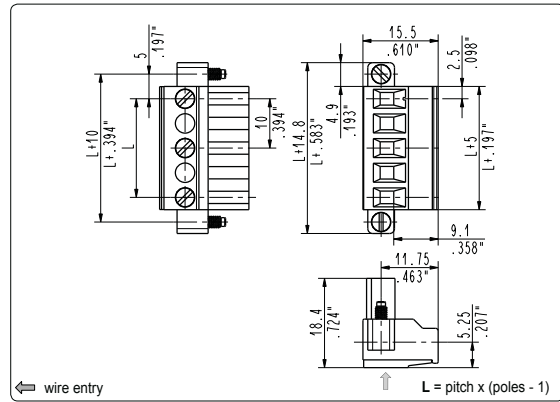

CIF_0V2 locking screw flanges, female

10 mm / .394" pitch

Poles	Code	Pcs/pack.	W [kg]*	Pcs/Ind.**	W [kg]*
02	CIF020V2	250	0,96	750	2,88
03	CIF030V2	175	0,94	500	2,68
04	CIF040V2	125	0,86	250	1,72
05	CIF050V2	100	0,84	250	2,10
06	CIF060V2	75	0,74	250	2,48
07	CIF070V2	75	0,86	250	2,86
08	CIF080V2	50	0,65	125	1,62
09	CIF090V2	50	0,72	125	1,81
10	CIF100V2	50	0,80	125	2,00
11	CIF110V2	50	0,88	125	2,19
12	CIF120V2	50	0,95	125	2,38

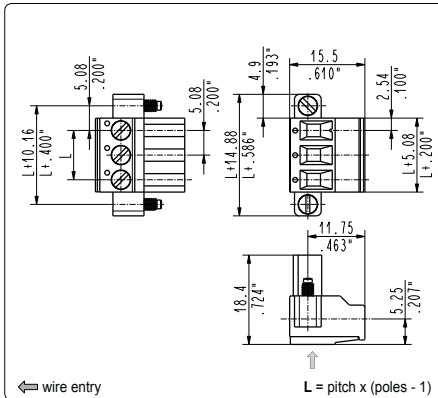

CIF_0V5 locking screw flanges, female

5.08 mm / .200" pitch

Poles	Code	Pcs/pack.	W [kg]*	Pcs/Ind.**	W [kg]*
02	CIF020V5	300	1,49	1000	4,96
03	CIF030V5	250	1,76	750	5,28
04	CIF040V5	200	1,82	500	4,56
05	CIF050V5	175	1,96	500	5,60
06	CIF060V5	150	1,99	500	6,64
07	CIF070V5	125	1,92	250	3,84
08	CIF080V5	100	1,74	250	4,36
09	CIF090V5	100	1,95	250	4,88
10	CIF100V5	75	1,62	250	5,40
11	CIF110V5	75	1,78	250	5,92
12	CIF120V5	75	1,93	250	6,44
13	CIF130V5	75	2,09	250	6,96
14	CIF140V5	75	2,24	250	7,48
15	CIF150V5	50	1,60	125	4,00
16	CIF160V5	50	1,70	125	4,26
17	CIF170V5	50	1,81	125	4,52
18	CIF180V5	50	1,91	125	4,78
19	CIF190V5	50	2,02	125	5,04
20	CIF200V5	50	2,12	125	5,30
21	CIF210V5	50	2,22	125	5,56
22	CIF220V5	50	2,33	125	5,82
23	CIF230V5	50	2,43	125	6,08
24	CIF240V5	50	2,54	125	6,34

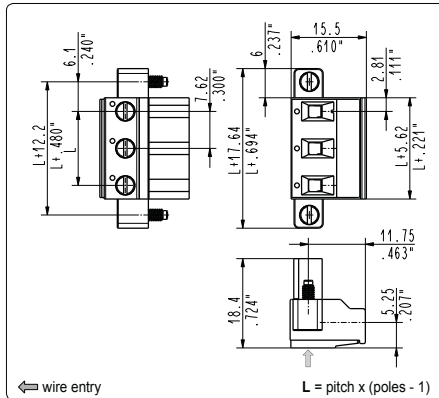

CIF_0V7 locking screw flanges, female

7.62 mm / .300" pitch

Poles	Code	Pcs/pack.	W [kg]*	Pcs/Ind.**	W [kg]*
02	CIF020V7	250	1,40	750	4,19
03	CIF030V7	175	1,39	500	3,99
04	CIF040V7	125	1,30	250	2,59
05	CIF050V7	100	1,28	250	3,19
06	CIF060V7	75	1,14	250	3,79
07	CIF070V7	75	1,31	250	4,38
08	CIF080V7	50	1,00	125	2,49
09	CIF090V7	50	1,12	125	2,79
10	CIF100V7	50	1,24	125	3,09
11	CIF110V7	50	1,35	125	3,39
12	CIF120V7	50	1,47	125	3,69

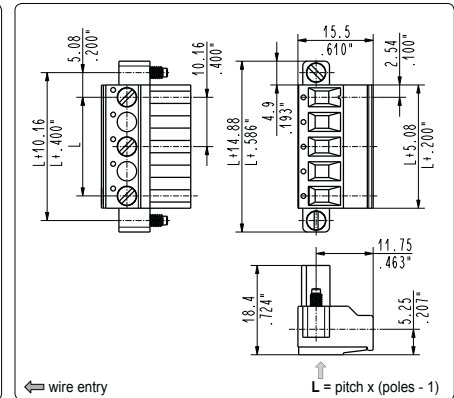

CIF_0V6 locking screw flanges, female

10.16 mm / .400" pitch

Poles	Code	Pcs/pack.	W [kg]*	Pcs/Ind.**	W [kg]*
02	CIF020V6	250	0,96	750	2,88
03	CIF030V6	175	0,94	500	2,68
04	CIF040V6	125	0,86	250	1,72
05	CIF050V6	100	0,84	250	2,10
06	CIF060V6	75	0,74	250	2,48
07	CIF070V6	75	0,86	250	2,86
08	CIF080V6	50	0,65	125	1,62
09	CIF090V6	50	0,72	125	1,81
10	CIF100V6	50	0,80	125	2,00
11	CIF110V6	50	0,88	125	2,19
12	CIF120V6	50	0,95	125	2,38

*W [kg]: approximate weight per box in kg

**industrial packaging: add "00000E" at standard code

