



Liquid Level Controls

dependable solid state devices for liquid level, photoelectric
temperature and process control

"We Build Confidence!"



Selection Chart

Series	Page Number	Supply Voltage	Load Capacity	Description and Special Notes
--------	-------------	----------------	---------------	-------------------------------

Curtis® liquid level controls

ELS	3	120, 240VAC	1/4 HP, 10 amp non-inductive 120VAC, 1/3 HP, 240 VAC	Economical liquid level control sensitivity range to 100,000 ohms
ELC	4	120, 240VAC	1/4 HP, 10 amp non-inductive 120VAC, 1/3 HP, 240 VAC	Low-cost liquid level control with sensitivity up to 50,000 ohms
LCT	5	24, 120, 240VAC	1/4 HP, 10 amp non-inductive 120VAC, 1/3 HP, 240 VAC	Liquid level control with built-in time delay feature for standard applications up to 100,000 ohms
LCS	6	24, 120, 240VAC	1/4 HP, 10 amp non-inductive 120VAC, 1/3 HP, 240 VAC	Liquid level control with adjustable sensitivity ranges for detection up to 100,000 ohms
LHS	6	24, 120, 240VAC	1/6 HP, 10 amp non-inductive 120VAC, 1/3 HP, 240 VAC	Liquid level control with adjustable sensitivity ranges for detection up to 3,00,000 ohms
LC	7	24, 120, 240VAC	1/4 HP, 10 amp non-inductive 120VAC, 1/3 HP, 240 VAC	Liquid level control with forward and reverse operating modes, adjustable sensitivity to 100,000 ohms
DLC	8	24, 120, 240VAC	1/6 HP, 10 amp non-inductive 120VAC, 1/3 HP, 240 VAC	Dual liquid level control with heater/pump lockout feature, sensitivity range to 100,000 ohms
Accessories	9			Rugged, compact contractors and enclosures meeting NEMA 1, 3, 4, and 12 specifications
Liquid level probe assemblies	9			A variety of pressure, temperature and fitting options available
RSA	10	24, 120, 240VAC		Low-cost amplifier module for liquid level applications

Curtis® industrial controls

ELS	11	24, 120, 240VAC	1/6 HP, 10 amp non-inductive 120VAC, 1/3 HP, 230 VAC	For precision photoelectric or temperature applications
-----	----	-----------------	--	---

Curtis® liquid level control principle of operation

Operating on the principle of conductivity (the ability of a liquid to conduct electricity), Curtis Liquid Level controls sense and control the level of almost any fluid or moist solid. These units are available with fixed or adjustable setpoints to control levels in fluids having an external circuit resistance up to 3,000,000 ohms. Typical solution resistivity is shown below.

Typical Liquid Resistivity

Liquid	Nominal Resistivity Range (ohms/CC)
acids, bases and salts	0-20
dilute acids	20-200
milk, beer	200-2,000
non-distilled water	2,000-20,000
distilled water	20,000-200,000

In operation, two or more submerged liquid level probes pass a minute electrical current through the liquid to be controlled. This

current, typically 500 microamperes, is introduced to a solid-state resistance-sending amplifier which provides sufficient gate signal to trigger a silicon-controlled rectifier (SCR). The firing threshold is accurate to within 2% of operating differential and is adjustable by means of a potentiometer. The output of the SCR is used to operate the plug-in control relay. When anticipated loads exceed that of the standard relay, an auxiliary contactor is utilized.

Control Models ELS, LCS/LHS, LCF and RSA are designed for forward mode operation. They interpret a decrease of external circuit resistance from setpoint as an "ON" signal. Model LCR is designed for reverse mode operation. It energizes when external circuit resistance increases above setpoint. Model DLC is intended primarily for pump and heater level/lockout applications. See the appropriate catalog sections for specific application information.

When selecting a liquid level control, several factors must be taken into consideration. Questions arise as to what mode of operation is required, what is the resistivity range of the fluid to be controlled, is a fixed or variable setpoint called for, are special functions required such as a pump or heater lockout, etc. Use the connection diagrams to select the ideal control for your specific application.

Curtis® liquid level controls

Model ELS

Economical unit with sensitivity up to 100,000 ohms

Features

- Solid State Amplifier with SCR and Control Relay
- Low AC Signal Voltage
- Compact Printed Circuit Design
- 1/4" Quick-Connect Terminals
- Insensitive to Transients
- Built-in Holding Circuit for Differential Levels or Manual Reset
- Plug-in Dust-Tight Relay
- Recognized Under the Components Program of Underwriters Laboratories, Inc. Listed with Canadian Standards Association.



Specifications

Input Supply:	Model ELS-1-A,B,C ELS-1-A,B,C	Input Supply 120VAC, 50/60 Hz 240VAC, 50/60 Hz	Maximum Signal or Probe Voltage: 24VAC Maximum Signal or Probe Current: 10MA
Maximum Allowable Supply Voltage Variation: ± 10%			Control Relay: Single Pole Double Throw, Plug-in Type with Dust-Tight Cover
Maximum Power Consumption: 3 Watts			Load Contacts: SPST Rated – 1/4 HP, 10 Amps, 120VAC 1/3 HP, 10 Amps, 240VAC
Detectable Range:	ELS-1,2-A ELS-1,2-B ELS-1,2-C	100,000 ohms 50,000 ohms 25,000 ohms	Ambient Operating Temperature: 32° F to 140° F Standard Termination: .250" Quick-Connects

Outline and Mounting Dimensions

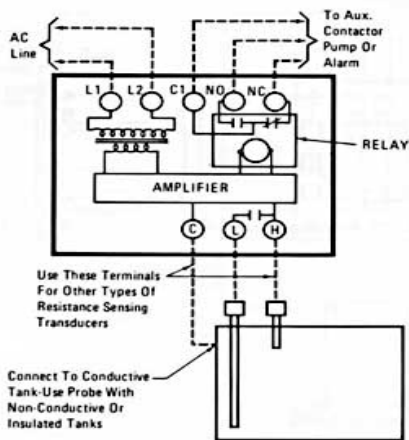

Connection Diagrams

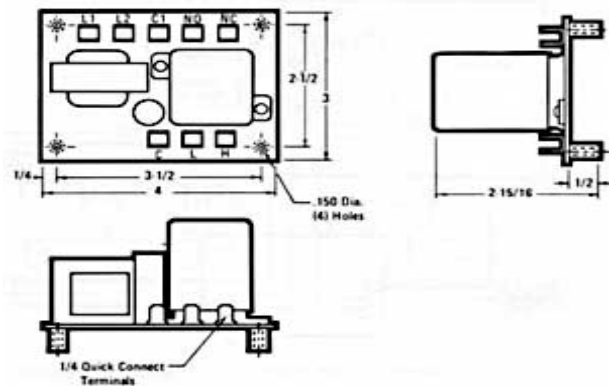

This is a fixed-sensitivity, forward mode control. The control relay is energized when liquid rises to contact the "H" probe. The control relay is pulled in and remains energized until liquid drops below the "L" probe.

Ordering Information

Typical Curtis Model Number

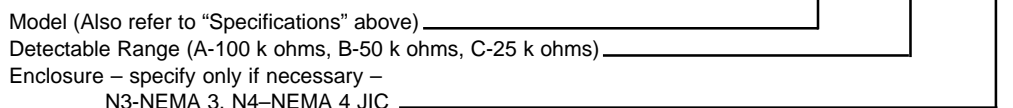

The composite number above reads as "an ELS amplifier for 120VAC supply, without enclosure, and with 100 K ohms sensitivity."

For further information on catalog listed controls contact your area Curtis representative or Curtis distributor.
 For custom design or modification contact your area Curtis Representative or the factory direct.

Curtis® liquid level controls

Model ELC

Economical unit with sensitivity up to 50,000 ohms

Features

- Compact, Solid-State Design
- Single Level, Forward Mode Operation
- Holding Circuit for Differential Levels, or Manual Reset
- Low AC Signal Voltage
- Transient-Protected Circuit, Positive ON/OFF Eliminates Relay Chatter
- Circuit Design Limits Short Circuit Probe Current to 10MA/24VAC



Specifications

Input Supply:	Model ELC-1-S,D ELC-1-S,D	Input Supply 120VAC, 50/60 Hz 240VAC, 50/60 Hz	Control Relay: Plug-in Type with Dust-Tight Cover
Maximum Allowable Supply Voltage Variation: ± 10%			Probe Contacts: SPDT internally connected
Maximum Power Consumption: 3 Watts			Load Contacts: SPDT (ELC-1,2-S) or DPDT (ELC-1,2-D) Rated 10 amp Non-inductive, 120VAC, 1/4 HP 1/3 HP at 240VAC
Detectable Range: Up to 50,000 ohms			Ambient Operating Temperature: +32° F to +140° F
Operating Point Differential: 3% (Typical)			Standard Termination: .250" Quick-Connect
Maximum Signal or Probe Voltage: 24VAC			Mounting Style: 4 Standoffs
Maximum Signal or Probe Current: 10MA			

Outline and Mounting Dimensions

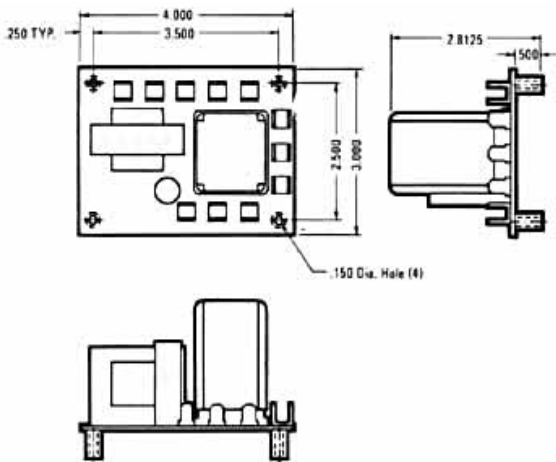

Connection Diagrams

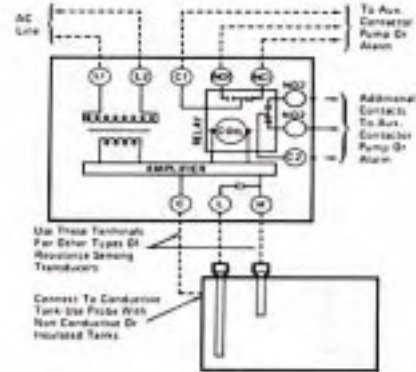

This is a fixed-sensitivity, forward mode control. The control relay is energized when liquid rises to contact the "H" probe. The control relay is pulled in and remains energized until liquid drops below the "L" probe.

Ordering Information

Typical Curtis Model Number

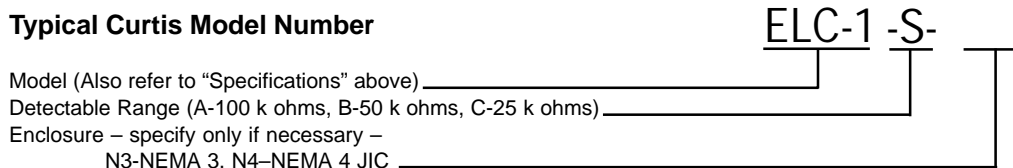

The composite number above reads as "an ELC amplifier for 120VAC supply SPDT Output and without Enclosure."

For further information on catalog listed controls contact your area Curtis representative or Curtis distributor.
 For custom design or modification contact your area Curtis representative or the factory direct.

Curtis® liquid level control with time delay

Model LCT

Features

- Low Cost Control for Standard Applications up to 100,000 ohms
- Built-in Delay-on-Make
- Interchangeable with Curtis Model LCS Liquid Level Controls
- Solid-State Amplifier with Potentiometer for Signal Sensitivity Adjustment
- Positive ON/OFF Operation Eliminates Relay Chatter
- Circuit Limits Short-Circuit Probe Current to 10MA/24VAC
- Holding Circuit for Differential Levels, or Manual Reset
- Pre-wired Auxiliary Contactor Available for Handling Heavy Loads and Motor Ratings Exceeding Capacity of Plug-in Relay

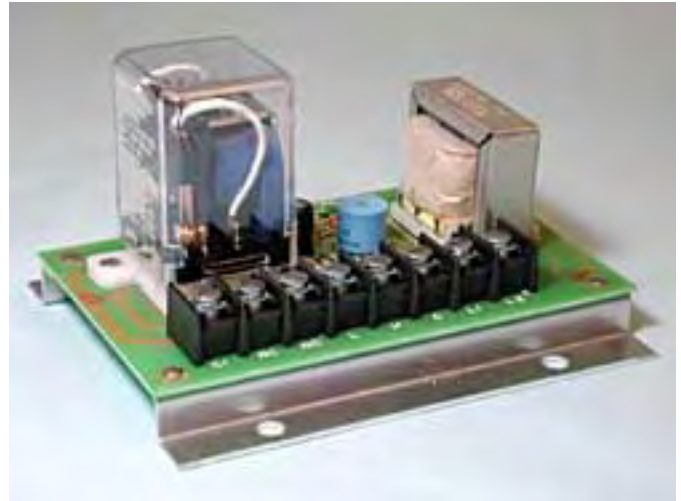

Specifications

	Model	Input Supply
Input Supply:	LCT-10	120VAC ±10%, 50/60 Hz
	LCT-20	240VAC ±10%, 50/60 Hz
	LCT-30	24VAC ±10%, 50/60 Hz.

Maximum Allowable Supply Voltage Variation: ± 10%

Maximum Power Consumption: 3 Watts

Sensitivity Range: 1,000 to 100,000 ohms

Detectable Range: Up to 100,000 ohms

Operating Point Differential: 3% (Typical)

Time Delay: Delay on Operate: 3 sec: ±50%

(Other values between 0.5 and 10 sec. available on request.)

Delay on Release: 0.5 sec. ±50%

Open Circuit Probe Voltage: 24VAC

Short Circuit Probe Current: 10MA

Control Relay: Plug-in type with dust cover

Contact Rating: 10 amp non-inductive, 1/4 HP at 120VAC, 1/3 HP at 240VAC

Auxiliary Contactor: DPST-NO-DB, rated 1 HP at 120VAC, 2 HP at 240VAC

Ambient Operating Temperature: 0° C to +60° C

Standard Termination: Barrier-type terminal blocks accepting wire up to No. 12AWG. Auxiliary contactor has combination screw/double .250" quick-connects

Mounting Style: Flange

Outside Dimensions: 5-1/2" long x 4-1/8" wide x 2-13/16" high

Outline and Mounting Dimensions

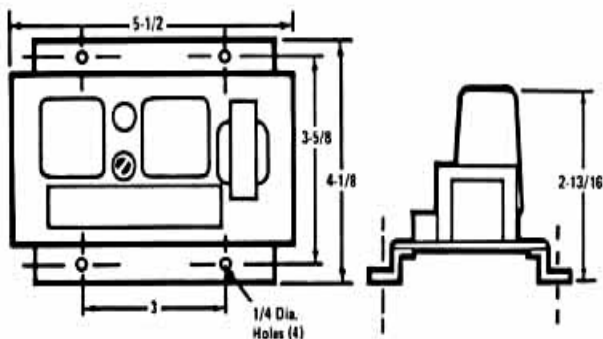

Connection Diagrams

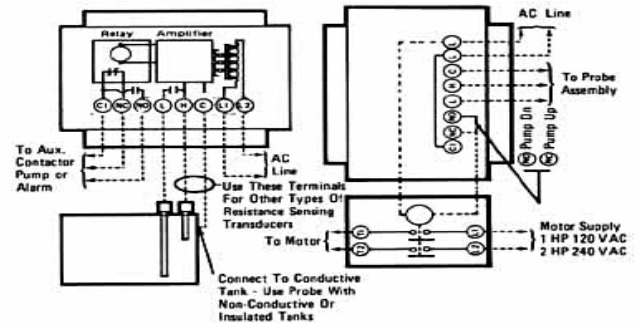

Model LCT is a forward mode control. The control relay is energized when liquid rises to contact the "H" probe. The time delay on operate is 3 seconds nominal and 0.5 seconds on release. Other values between 0.5 and 10 seconds are available on request. The control relay is pulled in and remains energized until liquid drops below the "L" probe. Sensitivity is adjustable.

Ordering Information

Typical Curtis Model Number

LCT-20 - -

Model (Also refer to "Specifications" above) _____

Contactors (add "C" if desired) _____

Enclosure - specify only if necessary -

N3-NEMA 3, N3C-NEMA 3/

Contactors, N4 - NEMA 4 JIC _____

The composite number above reads as an LCT amplifier for 240VAC supply, without enclosure and without contactor.

For further information on catalog listed controls contact your area Curtis Representative or Curtis distributor.

For custom design or modification contact your area Curtis Representative or the factory direct.

Curtis® liquid level controls with

Models LCS/LHS

Two sensitivity ranges for detection up to 3,000,000 ohms

Features

- Low cost Model LCS for Standard Applications up to 100,000 ohms
- High-Sensitivity Model LHS for Special Applications from 100,000 to 3,000,000 ohms
- Solid-State Amplifier with Potentiometer for Signal Sensitivity Adjustment
- Positive ON/OFF Operation Eliminates Relay Chatter
- Circuit Limits Short Circuit Probe Current to 10MA/24VAC
- Holding Circuit for Differential Levels, or Manual Reset
- Pre-Wired Auxiliary Contactor Available for Handling Heavy Loads and Motor Ratings Exceeding Capacity of Plug-In Relay



Specifications

	Model	Input Supply
Input Supply:	LCS-10/LHS-1	120VAC, 50/60 Hz
	LCS-20/LHS-2	240VAC, 50/60 Hz
	LCS-30	24VAC, 50/60 Hz.
Maximum Allowable Supply Voltage Variation: ± 10%		
Maximum Power Consumption: 3 Watts		
Detectable Range: Up to 100,000 ohms (LCS); Up to 3,000,000 ohms (LHS)		
Adjustable Range: 1,000 to 100,000 ohms (LCS); 1,000 to 3,000,000 ohms (LHS)		
Operating Point Differential: 3% (Typical)		
Signal or Probe Voltage: 24VAC		
Maximum Signal or Probe Current: 10MA		

Short Circuit Probe Current: 10MA
Control Relay: Plug-in type with dust cover
Probe Contacts: Internally Connected for Holding Circuit
Load Contacts: LCS – SPDT, 1/4 HP, 10 amp Non-inductive, 120VAC 1/3 HP at 240 VAC
 LHS – SPDT, 1/6 HP, 10 amp Non-inductive, 120VAC 1/3 HP at 240VAC
Auxiliary Contactor: DPST-NO-DB, rated 1 HP at 120VAC, 2 HP at 240VAC
Ambient Operating Temperature: +32° F to +140° F
Standard Termination: Barrier-type terminal blocks accepting wire up to No. 12AWG. Auxiliary contactor has combination screw/double .250" quick-connects
Mounting Style: Flange

Outline and Mounting

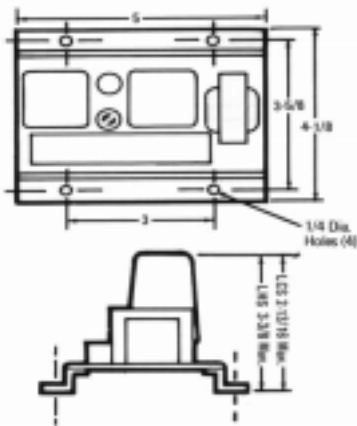

Connection Diagrams

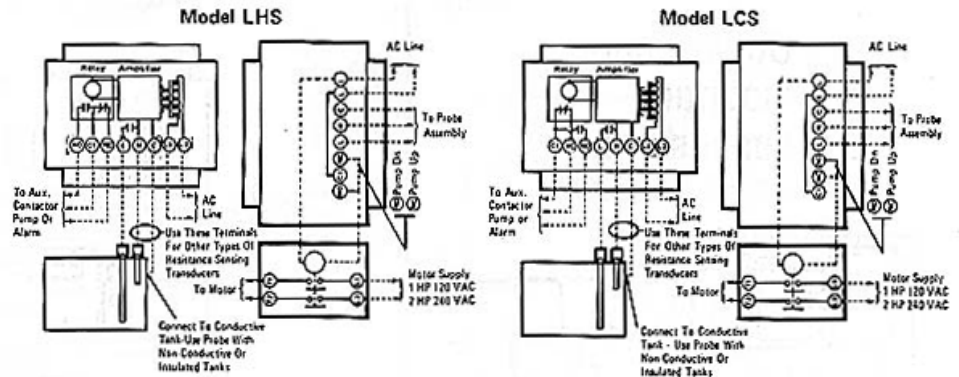

Models LCS/LHS is a forward mode control. The control relay is energized when liquid rises to contact the "H" probe. The control relay is pulled in and remains energized until liquid drops below the "L" probe. Sensitivity is adjustable.

Ordering Information

Typical Curtis Model Number

Model (Also refer to "Specifications" above) _____

Contactor (add "C" if desired) _____

Enclosure – specify only if necessary –
 N3-NEMA 3, N3C-NEMA 3/
 Contactor, N4 – NEMA 4 JIC _____

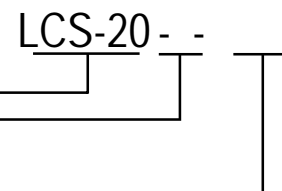

The composite number above reads as an LCS amplifier for 240VAC supply, without enclosure and without contactor. For further information on catalog listed controls contact your area Curtis representative or Curtis distributor. For custom design or modification contact your area Curtis representative or the factory direct.

adjustable setpoints

Model LC

Forward or reverse, mode with single or differential level operation

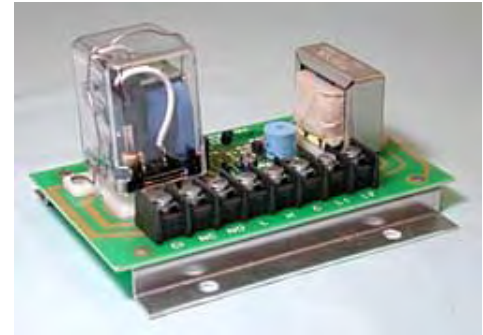

Features

- Adjustable Sensitivity up to 100,000 ohms
- Solid State Amplifier with SCR and Control Relay
- Circuit Limits Short Circuit Probe Current 10MA/24VAC
- Recommended for Applications Having Longer Than Average Probe Runs. (Resultant Line Capacitance can be Compensated for by Adding a Capacitor (CX) of Equivalent Value to Available Terminals or the Control)
- Temperature-Stabilized from +32° F to +140° F
- Shielded, Grounded Isolation Transformer
- Low Power Consumption
- Auxiliary Contactor Available

Specifications

Model	Input Supply	Model	Input Supply
Input Supply: LC-F-1	120VAC, 50/60 Hz	LC-R-1	120VAC, 50/60 Hz
LC-F-2	240VAC, 50/60 Hz	LC-R-2	240VAC, 50/60 Hz
LC-F-3	24VAC, 50/60 Hz	LC-R-3	24VAC, 50/60 Hz

- Maximum Allowable Supply Voltage Variation:** ± 10%
- Maximum Power Consumption:** 3 Watts
- Detectable Range:** Up to 100,000 ohms
- Adjustable Range:** 1,000 to 100,000 ohms
- Operating Point Differential:** 3% (Typical)
- Signal or Probe Voltage:** 24VAC
- Maximum Signal or Probe Current:** 10MA
- Control Relay:** Plug-in type with dust cover
- Probe Contacts:** Internally connected for holding circuit
- Load Contacts:** DPDT rated 10 amp, Non-inductive/120VAC, 1/4 HP at 240VAC
- Auxiliary Contactor:** DPST-NO-DB, rated 1 HP at 120VAC, 2 HP at 240VAC
- Ambient Operating Temperature:** +32° F to +140° F
- Standard Termination:** Barrier-type terminal blocks for wire up to No. 12AWG. Auxiliary contactor has combination screw/double .250" quick-connects. Optional SPDT contacts have .250" quick-connects
- Options:** Alarm and indicator lamp for enclosure-mounted controls, high impedance relays available for extended control dropout time.=
- Mounting Style:** Standoffs

Outline and Mounting Dimensions

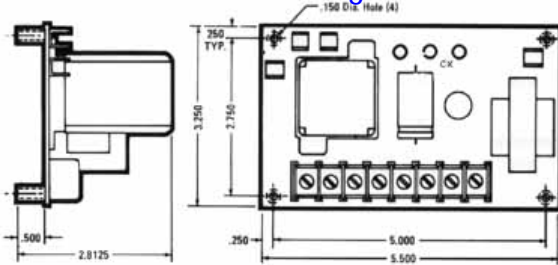

Connection Diagrams

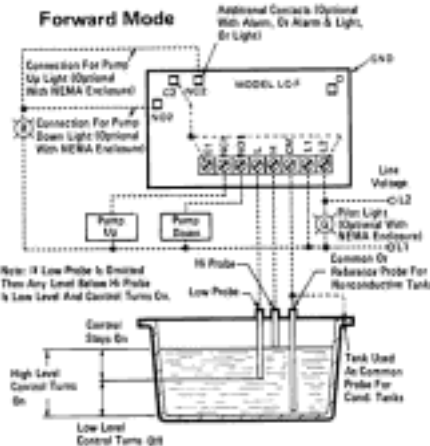

Model LC – Forward Mode

Control energizes when liquid reaches "H". Control de-energizes when liquid falls below "L" and remains in an off state until liquid again reaches "H". This control maintains a liquid level between "H" and "L" and will not chatter due to surface ripple.

Single Level Operation (Not Illustrated)

both the LC-F and LC-R may be used without the "L" Probe. Operation without the "L" Probe gives a very small differential between the energize and de-energize levels. This may result in chattering of the control if splashing or ripple is present at the liquid surface.

Model LC – Reverse Mode

Control Energizes when liquid falls below "L". Control remains energized until liquid rises past "L" and contacts "H". Control de-energizes when liquid reaches "H" and remains in an off state until liquid again falls below "L". This control maintains a liquid level between "L" and "H" and will not chatter due to surface ripple.

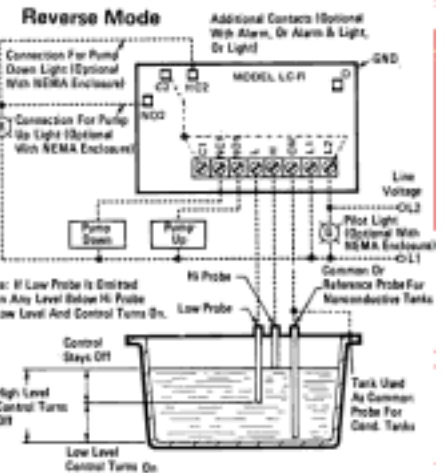

Ordering Information

Typical Curtis Model Number

Model (Also refer to "Specifications" above) _____
 Operational Mode (F – Forward, R – Reverse) _____
 Contactor (add "C" if desired) _____
 Enclosure – specify only if necessary –
 N3-NEMA 3, N3C-NEMA 3/
 Contactor, N4 – NEMA 4 JIC _____

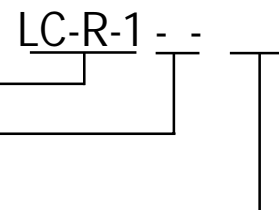

The composite number above reads as an LC amplifier with reverse mode, for 120VAC supply, without enclosure and without contactor."
 For further information on catalog listed controls contact your area Curtis representative or Curtis distributor.
 For custom design or modification contact your area Curtis representative or the factory direct.

Curtis® liquid level controls

Models DLC

Dual-level control with lockout feature

Features

- Ideal for Pump and Heater Applications Requiring Lockout in the Event of Loss of Water or Product Being Controlled
- Circuit Design Limits Short Circuit Probe Current to 10MA/24VAC
- Three-Probe Circuit Eliminates "Hunting" or Relay Chatter
- Built-in Holding Circuit for Differential Levels or Manual Reset
- Has Provision for Priming Switch for Applications Requiring Manual Priming of System
- Solid-State Amplifier with SCR and Control Relay
- Sensitivity to 100,000 ohms

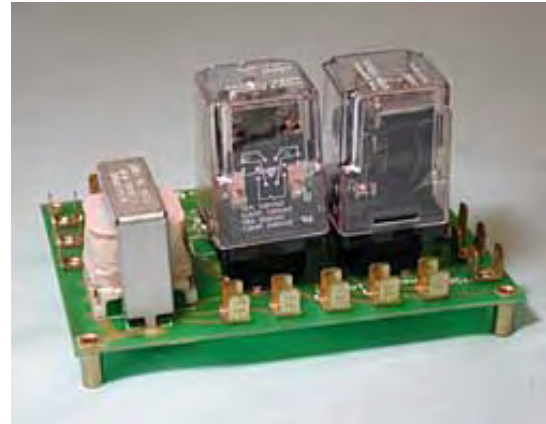

Specifications

	Model	Input Supply
Input Supply:	DLC-1	120VAC, 50/60 Hz
	DLC-2	240VAC, 50/60 Hz
	DLC-3	24VAC, 50/60 Hz.

Maximum Allowable Supply Voltage Variation: ± 10%

Maximum Power Consumption: 3 Watts

Sensitivity Range: External circuit sensitivity fixed at 100,000 ohms; Lockout circuit sensitivity fixed at 15,000 ohms

Operating Point Differential: 3% (Typical)

Maximum Signal or Probe Voltage: 24VAC

Maximum Signal or Probe Current: 10MA

Control Relay: Plug-in types with dust cover

Probe Contacts: Internally connected for holding circuit

Load Contacts: 1/6 HP, 10 amp, Non-inductive/120VAC, 1/3 HP at 240VAC

One side of No. 1 relay actuates fill water solenoid valve, a second set of contacts function as an internally connected holding circuit. One side of No. 2 relay is used to operate a heater load contactor.

Ambient Operating Temperature: +32° F to +140° F

Standard Termination: .250" quick-connects

Outline and Mounting Dimensions

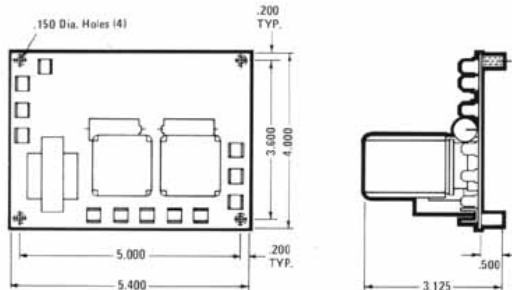

Description and Special Notes

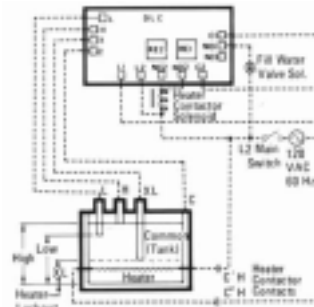

The DLC control maintains liquids between a low and a high level. Activating the main switch on this dual-relay unit pulls in control relay No. 1 and starts filling boiler tank through the solenoid valve. When liquid rises to "XL", minimum level, lockout control relay No. 2 energizes to operate the pump, heater core or contactor. The solenoid valve continues to fill the tank until liquid reaches the "H" probe. When the liquid drops below the "L" probe, the solenoid fill valve is again activated. Relay No. 2, he lockout control, remains energized as long as liquid level remains above "XL" minimum level.

Ordering Information

Typical Curtis Model Number

Model (Also refer to "Specifications" above) DLC-1 - -

Contactor (add "C" if desired) _____

Enclosure – specify only if necessary –
 N3-NEMA 3, N3C-NEMA 3/
 Contactor, N4 – NEMA 4 JIC _____

The composite number above reads as a "DLC amplifier for 120VAC supply, without enclosure and without contactor.

Unless otherwise noted, when a contactor is ordered for the DLC unit, it is wired into the output of the No. 2 (heater control) relay. Contactors may be wired into the output of the No. 1 (solenoid valve control) relay or both No. 1 and No. 2 relays, as application may require. Specify with order. Refer to "Control Accessories," page 7, for additional information.

For further information on catalog listed controls contact your area Curtis representative or Curtis distributor.

For custom design or modification contact your area Curtis representative or the factory direct.

Curtis® liquid level probe assemblies

P Series

Probes for almost any pressure/temperature requirement

Five basic probe types and 14 model variations provide design versatility matched to your specific application. Choose from single, dual or multi-probe designs in PVC or nylon fittings. All probes feature 316 stainless steel electrodes with standard lengths ranging up to six feet, in one-foot increments. Pressure/temperature limits range as high as 2500 lbs./700° F. Covered probes are offered for applications subject to unusually adverse environments or stringent safety codes.



Model EP

Economy probe designed for budget systems. Available in NPT sizes 3/4" (Single probe), 1" (Dual probe), 1-1/2" (Triple probe) with Nylon Hex fittings.



Model SP

Simple probe designed with adjustable probe length feature. Must be used with conductive container only. Available in probe size diameters of 1/8", 3/16" or 1/4" (i.e. SP125, SP187, SP250).



Models HTPP - HTPGP

High temperature, high pressure 3/8" NPT probe designed to withstand hydrostatic pressures to 2500 psi and temperatures to 700° F. Standard Model HTPP does not contain added threaded stud for common ground connection, when required specify HTPGP Model. Constructed from 18-8 non-magnetic stainless steel with alumina insulation.



Model CP

Covered Probe designed for high humidity environments. Probe headers are splash-proof and moisture-tight. Available in NPT fitting sizes 1-1/2" for dual probe systems and 2" for triple or quadruple probe systems.



Accessories

Control enclosures for hostile environments

Standard Control Models ELS, LCS/LHS, LC, RSA, DLC, and PCT are open-style. Models with contactors are attached to a 6-7/8" x 8-3/4" panel. NEMA 3 and MEA 4-JIC enclosures are offered to fit above models with or without contactor mounting panels. Alarm and indicator lamp options are also available. Contact factory or your local representative for additional information.

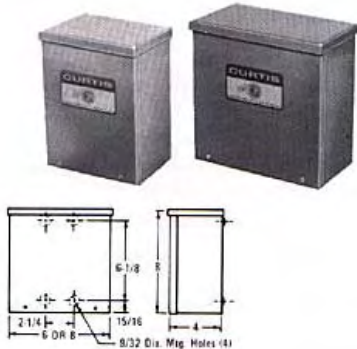

NEMA 3 Enclosures – Weather-Resistant for Outdoor Applications

Designed to exclude rain, snow and sleet, these durable enclosures may also be used indoors wherever dripping water presents a problem. Construction features heavy-gauge steel finished in satin gray enamel. Enclosures accepting standard control models are designated N3, while those accepting the larger contactor mounting panels are designated N3C. Enclosures also meet NEMA I specifications for general purpose dust resistance.

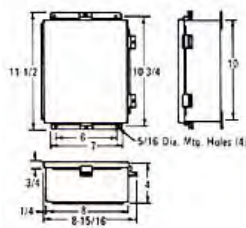

NEMA 4-JIC Enclosures – Water Tight and Oil Tight

Intended for use in areas which are regularly hosed down. They are suitable for outdoor, shipdeck, dairy or brewery applications. Enclosures are fabricated of extra-heavy 14-gauge steel with welded seams. Construction also features external mounting feet and solid neoprene cover gasket. These grey hammertone enamel-finished units accept standard and contactor mounting panel controls. Enclosures also meet NEMA 12 for dust, dirt and oil protection.

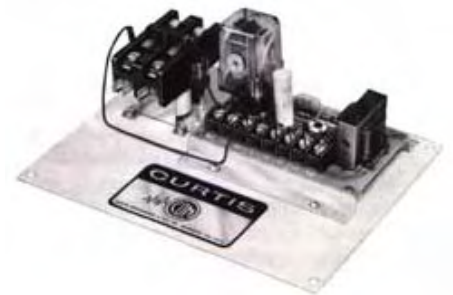

Auxiliary Contactors – For Loads Exceeding That of Standard Relays

When anticipated loads exceed the 10 amp/120VAC rating of relays furnished with our standard controls, use of a contactor is necessary. These small, ruggedly built units are available in 24, 120 and 240VAC coil voltages to match the control input supply voltage. Contactors feature heavy-duty DPST-NO-DB contacts rated 1HP/120VAC or 2HP/240VAC. Terminals are No. 10 pressure screws with .250" double quick-connect tabs. Contactor/control assemblies are prewired for customer convenience.

Any standoff or flange-mounted control may be ordered with the auxiliary contactor. Track-mounted controls are available with auxiliary contactors on special order only. Contact factory for additional info.

Any standoff or flange-mounted control may be ordered with the auxiliary contactor. Track-mounted controls are available with auxiliary contactors on special order only. Contact factory for additional information.

Curtis® low cost amplifier module for liquid level applications

Model RSA Control-Trak® component



Features

- Inexpensive, Compact Circuitry is Compatible with any Transducer Exhibiting 100,000 ohms Resistance or Less
- Designed to Fit Curtis TR1 or TR3 Snap-In Track Intended for Use with Curtis RS2, RS4, RS6, RS12, RS15 or RS16 Relay Socket Assemblies (See Curtis Relay Socket Catalog)
- Ideal for Custom, Modified or Experimental Circuits – Control/Relay Socket Combination Provides Access to the Several Hundred Relay Styles Available from Most Relay Manufacturers
- Devices Other Than Relays, such as Solenoids or Valve Actuators may be Operated Directly Off the Module Providing that They are Rated 24VDC with Impedance Greater than 250 ohms
- Includes Fully Adjustable Setpoint and Circuit Designed to Limit Maximum Direct-Short Transducer Current to 10MA/24VAC

Specifications

	Model	Input Supply
Input Supply:	RSA-1	120VAC, 50/60 Hz
	RSA-2	240VAC/ 50/60 Hz
	RSA-3	24VAC, 50/60 Hz
Maximum Allowable Supply Voltage Variation: ± 10%		
Maximum Power Consumption: 1 W without relay		
Detectable Range: Up to 100,000 ohms		
Adjustable Range: 1,000 to 100,000 ohms		
Operating Point Differential: 3% (Typical)		
Maximum Signal or Probe Voltage: 24VAC		
Maximum Signal or Probe Current: 10MA		
Control Relay: Customer furnished – See Curtis Relay Socket Catalog for complete list of various snap-in assemblies		
Control Output: 90MA @ 24VDC		
Ambient Operating Temperature: 0° C to +60° C or ±32° F		
Standard Termination: .110" quick-connects		

Outline and Mounting Dimensions

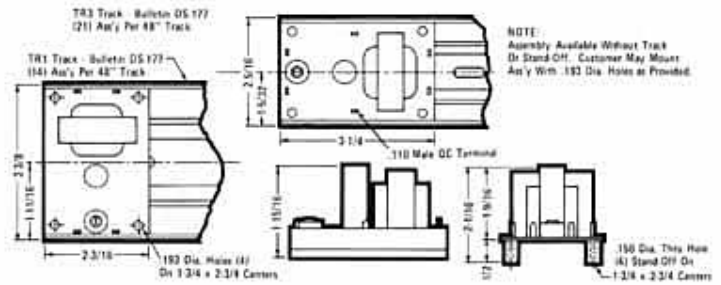

Operation

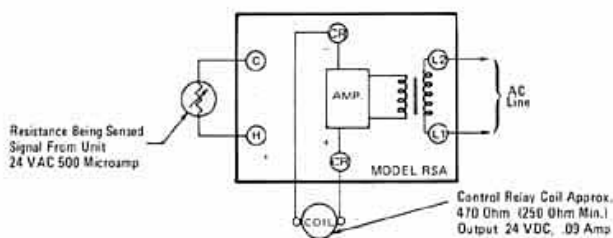

Model RSA Amplifier Module accepts any liquid level transducer displaying less than 100,000 ohms resistance. As an example of its operation as a liquid level control, the control remains de-energized until liquid rises to contact the "H" probe. The resultant decrease in external circuit resistance from setpoint will energize output. Output remains energized until liquid again drops below the "H" probe. Sensitivity of the external circuit resistance setpoint is fully adjustable up to 100,000 ohms. Model RSA is designed to work in conjunction with track-mounted, customer supplied relays. However, the 90MA/24VDC output is sufficient to operate many solenoid and valve devices directly when minimum impedance exceeds 250 ohms.

Ordering Information

Typical Curtis Model Number

Basic Amplifier Type (Also refer to "Specifications" above) _____
Mounting (TR-Track, S-Standoff) _____

RSA-1 -TR -

The composite number above reads as a "RSA amplifier for 120VAC supply." Model is track mounted (track ordered separately – see page 11.) An auxiliary contactor offered as a track-mounted accessory is available on special request only. Track-type units cannot be enclosure-mounted. Contact factory for additional information.

For further information on catalog listed controls contact your area Curtis representative or Curtis distributor. For custom design or modification contact your area Curtis representative or the factory direct.

Curtis[®] resistance sensing amplifier for photoelectric, temperature and process control

Model PCT

Features

- Zener Diode-Regulated Power Supply Limits Operating Point Variations to Less than 0.5%
- Standard Adjustable Resistance Sensing Range is Sensitive to 100,000 ohms but can be extended to 250,000 ohms
- Has Provision for Remote Potentiometer Adjustment of Operating Setpoint as well as Built-In Time Delay which can be Modified to Meet Individual Customer Specifications
- May be Wired for Light or Dark Energizing Operation
- Circuit Design Limits Short Circuit Transducer Current to a Maximum 4MA/9VDC
- Auxiliary Contactor Available for Loads Exceeding Capacity of Plug-in Relay
- Differential Adjustment Provided
- Auxiliary Contactor Available for Loads Exceeding Capacity of Plug-in Relay

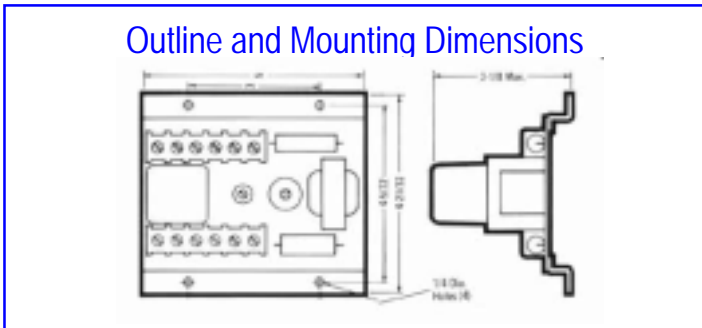

Operation

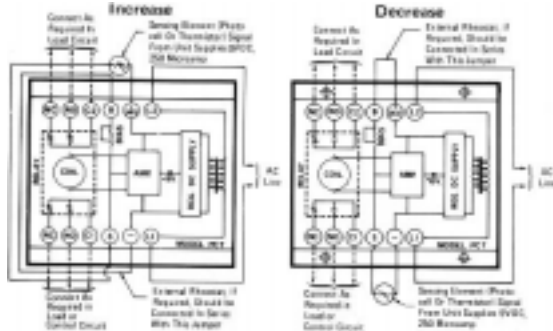

Ordering Information

Typical Curtis Model Number

Basic Amplifier Type (Also refer to "Specifications" above) _____
 Contactor (if desired add "C") _____
 Enclosure – specify only if necessary
 (N3 – NEMA 3, N3C – NEMA 3/
 Contactor, N4 – NEMA 4 JIC

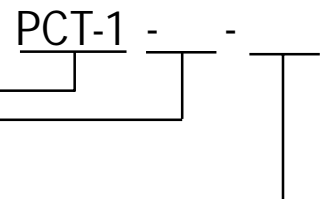

The composite number above reads as a "PCT amplifier for 120VAC supply without contactor and less enclosure." Contact factory for additional information.

For further information on catalog listed controls contact your area Curtis representative or Curtis distributor. For custom design or modification contact your area Curtis representative or the factory direct.



Specifications

	Model	Input Supply
Input Supply:	PCT-1	120VAC, 50/60 Hz
	PCT-2	240VAC/ 50/60 Hz
	PCT-3	24VAC, 50/60 Hz
Maximum Allowable Supply Voltage Variation: ± 10%		
Maximum Power Consumption: 3.5 Watts		
Detectable Range: Up to 100,000 ohms Standard; may be extended to 250,000 ohms		
Adjustable Range: 1,000 to 100,000 ohms Standard; 1,000 to 250,000 ohms for extended sensitivity circuits		
Operating Point Differential: 1% (With Sensing Element Resistance Above 15k ohms) Typical		
Maximum Signal or Probe Voltage (Element Exhibiting Infinite Resistance): 9VDC		
Maximum Signal or Probe Current: 4MA		
Control Relay: DPDT Plug-In Type with Cover		
Load Contacts: 1/6 HP, 10 amp, Non-inductive/120VAC; 1/3 HP at 230VAC		
Ambient Operating Temperature: -25° F to +140° F		
Standard Termination: Barrier-Type Terminal Blocks. Accepting Wire up to No. 12AWG		
Mounting Style: Flange		

Model PCT control may be wired to energize the control relay following either an increase or a decrease in external circuit resistance. Unit provides a .25MA/9VDC signal to a variable resistance sensing element. A control-mounted potentiometer allows adjustment of pull-in or drop-out point. The unit has provision for extension of the operating point as well as remote potentiometer adjustment. A built-in time delay eliminates false rigging due to minor sensing element impulses. Standard response time, typically 100 milliseconds, can be altered by changing the value of capacitor C₂. Provides a response time of 10 to 15 milliseconds.